

# Instruction Manual



# pipet4u<sup>®</sup> pro

## MICRO VOLUME PIPETTE



**FMCG Industry Solutions Pty Ltd**

ABN 22 135 446 007

📍 Factory 11A, 1 – 3 Endeavour Rd, Caringbah NSW 2229

🌐 [www.fmcgis.com.au](http://www.fmcgis.com.au)

✉ [sales@fmcgis.com.au](mailto:sales@fmcgis.com.au)

☎ 1300 628 104 or 02 9540 2288



# Table of contents

<b>GENERAL INFORMATION</b>	<b>5</b>
<b>INTENDED USE</b>	<b>5</b>
<b>SAFETY</b>	<b>5</b>
<b>DELIVERY PACKAGE</b>	<b>5</b>
<b>CALIBRATION/DISASSEMBLING TOOL</b>	<b>5</b>
<b>PIPETTE IDENTIFICATION</b>	<b>5</b>
<b>PIPETTE DESCRIPTION</b>	<b>6</b>
<b>SEALING AND EJECTING TIPS</b>	<b>7</b>
<b>VOLUME SETTING</b>	<b>7</b>
<b>FORWARD PIPETTING</b>	<b>8</b>
<b>REVERSE PIPETTING</b>	<b>8</b>
<b>PIPETTING RECOMMENDATIONS</b>	<b>9</b>
<b>MAINTENANCE</b>	<b>9</b>
<b>DISASSEMBLING/REASSEMBLING AND CLEANING</b>	<b>9-10</b>
<b>AUTOCLAVING</b>	<b>10</b>
<b>CALIBRATION</b>	<b>10</b>
<b>CHECKING CALIBRATION</b>	<b>10-11</b>
<b>RECALIBRATION</b>	<b>11</b>
<b>WARRANTY</b>	<b>11</b>
<b>RETURNING</b>	<b>11</b>
<b>TROUBLE SHOOTING</b>	<b>12</b>
<b>PIPETTE TOP ASSEMBLY PARTS SINGLE CHANNEL PIPETTES</b>	<b>13</b>
<b>PIPETTE BOTTOM ASSEMBLY PARTS SINGLE CHANNEL PIPETTES</b>	<b>14</b>
<b>SPECIFICATIONS</b>	<b>15</b>



**General information** - The **pipet4u<sup>®</sup> pro** pipettes are piston-operating pipettes for accurate and precise sampling and dispensing of liquid volumes in the range from 0.1 µl to 10 ml. They operate according to the air displacement principle and are produced and tested according to EN ISO 8655. The **pipet4u<sup>®</sup> pro** pipettes are available as single channel pipettes with variable and fixed volume and multi channel pipettes with variable volume.

**Intended use** - The **pipet4u<sup>®</sup> pro** pipettes, used in conjunction with the matching pipette tip(s), are intended for laboratory use as in-vitro diagnostica accessory with the in-vitro diagnostica product and as stand alone laboratory equipment (Directive 98/79/EC) and are intended for operation by professional staff.

**Safety** - Before using the device, the instruction manual must be read. Follow the safety instruction, wear protective equipment while using the device, especially when working with infectious and dangerous samples. Work in such a way that neither user nor other persons are endangered. Only use the pipette with conform tips. Check the proper condition of the device before each use.

## Delivery Package

- 1 pc. Pipette
- 1 pc. Calibration/disassembling tool
- 1 pc. Tool to remove colour coding drop
- 1 pc. Silicon grease
- 1 bag Drop for colour coding
- 1 bag Sample tips
- 1 bag O-rings (available for multi channel pipettes)
- 1 pc. Instruction manual
- 1 pc. Warranty card
- 1 pc. Calibration report according to EN ISO 8655

**Calibration/disassembling tool** - The included tool is designed for easy and quick maintenance and calibration of the pipette.

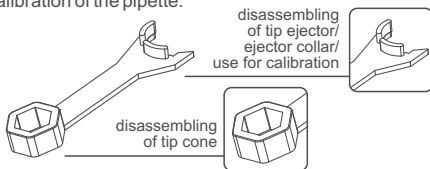

**Pipette identification** - Each **pipet4u<sup>®</sup> pro** pipette can be individually colour coded, using the included tool for drop removing.

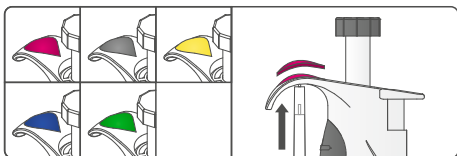

# Instruction manual

## Pipette description

### pipet4u® pro

Single channel pipette

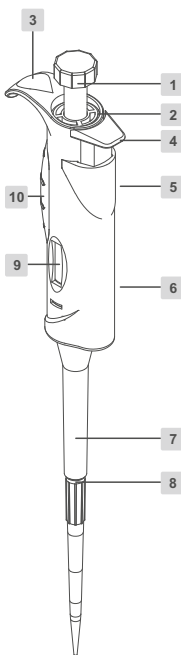

#### 1. Push button

It is used to aspirate and dispense the liquid and to set the volume (variable volume pipettes)

#### 2. Top closure

It is used to adjust the calibration with the help of the calibration tool

#### 3. Drop

The drop is colour coded as per the volume of the pipette for easy identification

#### 4. Tip ejector

Tip ejector moves the ejector collar and ejects the pipette tip

#### 5. Volume print

It indicates the volume of the pipette

#### 6. Main body

#### 7. Ejector collar

It is used to eject the pipette tip

#### 8. Tip cone

It is the part where the pipette tip is fitted

#### 9. Volume display

It shows the volume set with the push button (variable volume pipettes) and the nominal volume of fixed volume pipette

#### 10. Body grip

It prevents transfer of body heat to internal components to ensure accurate pipette operation and also provides proper grip while holding the pipette

## Sealing and ejecting tips

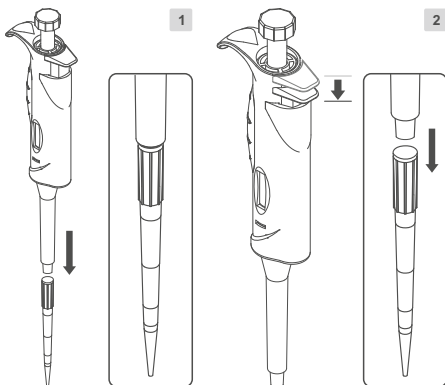

Before fitting the tip(s) make sure that the tip cone(s) is/are clean. Use the correct tip according to the volume range or the colour code. Press the tip(s) firmly onto the tip cone(s) to ensure an airtight seal (1). The pipettes are equipped with a tip ejector to help eliminate the tip(s) and to avoid safety hazards associated with contamination. The tip ejector needs to be pressed downwards to ensure proper tip ejection (2). (for 10000  $\mu$ l and 2000-10000  $\mu$ l pipettes tip ejection function is not available).

## Volume setting

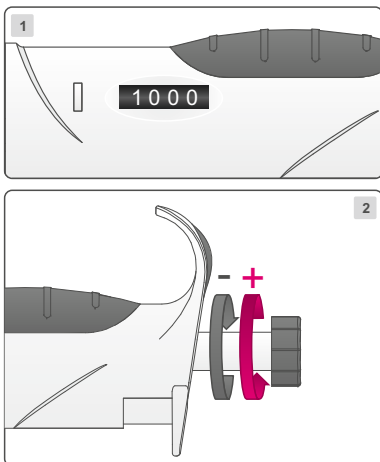

The volume of the **pipet4u<sup>®</sup> pro** pipette is shown through the handgrip window (1). For the variable pipettes, the desired volume is set by turning the push button clockwise or anticlockwise (2). Using excessive force to turn the push button outside the range may jam the mechanism and damage the pipette.

## Forward pipetting

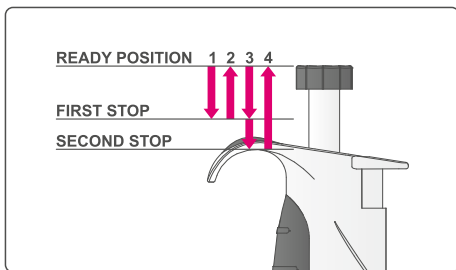

Press the push button to the first stop **(1)**. Dip the tip(s) attached to the pipette vertically 2-3 mm into the liquid and smoothly release the push button **(2)**. Withdraw the tip(s) slowly from the liquid, touching against the wall of the vessel to remove remaining liquid. Place the tip(s) on the wall of the vessel in an angle. Dispense the liquid into the receiving vessel by gently pressing the push button to the first stop **(3)**. After a short delay press the push button to the second stop **(3)**. This blow-out will empty the tip(s) completely and ensure accurate pipetting. Release the push button to the ready position **(4)**.

## Reverse pipetting

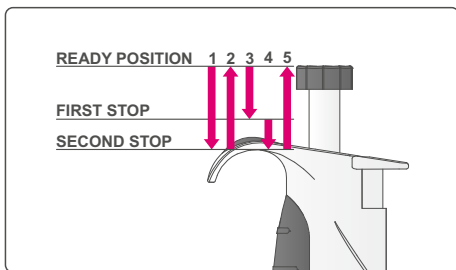

Reverse pipetting is recommended for viscous solutions, solutions having tendency to foam or dispensing very small volumes. Press the push button to the second stop **(1)**. Dip the tip(s) attached to the pipette vertically 2-3 mm into the liquid and smoothly release the push button **(2)**. This will fill the tip(s) with a additional volume larger than the set volume. Withdraw the tip(s) slowly from the liquid, touching against the wall of the vessel to remove excess liquid. Dispense the liquid into the receiving vessel by gently pressing the push button to the first stop **(3)**. This volume is equal to the set volume. Hold the push button in this position. The liquid that remains in the tip should not be dispensed. The remained liquid can be discarded with the tip or delivered back into the vessel with the original solution **(4)**. Release the push button to the ready position **(5)**.



**Pipetting recommendations** - Aspirate liquid into the pipette only when a tip(s) is/are attached. Hold the pipette vertically when aspirating and dip the tip(s) only 2-3 mm into the liquid. Pre-rinse the tip(s) 5 times before aspiration by filling and emptying the tip(s). Always control the push button movements with the thumb for consistency. Allow liquid, tip(s) and pipette to equilibrate to the ambient temperature before use. Don't keep the pipette in your hand while not working to avoid transferring body heat resulting in incorrect dispensing volume. Use the correct pipette tip(s) designed for the use with the particular pipette. Select the correct pipetting technique (e.g. reverse, forward pipetting) depending on the nature of the liquid. Don't lay down the pipette with the filled tip, otherwise the liquid can flow into the pipette and contaminate it.

**Maintenance** - It is recommended to check the performance of your pipette regularly e.g. every 3 months and always after in-house service or maintenance. To maintain the best results from your pipette, each unit should be checked every day for cleanliness. Pay special attention to the tip cone(s).

## Disassembling/reassembling and cleaning

To clean and decontaminate or replace the lower parts of the single channel pipette, proceed as follows:

1. Hold down the tip ejector.
2. Place the tooth of the opening tool between tip ejector and tip ejector collar to release the locking mechanism.
3. Carefully release the tip ejector and remove the ejector collar.
4. Place the wrench end of the opening tool over the tip cone and turn it clockwise.
5. After removing the tip cone, wipe the piston, the o-ring and the tip cone with ethanol and a lint free cloth. (cleaning step)
6. Before replacing the tip cone grease the piston slightly using the silicon grease provided. (cleaning step)
7. After reassembling use the pipette several times to make sure that the grease is spread evenly.
8. Check the calibration of the pipette.

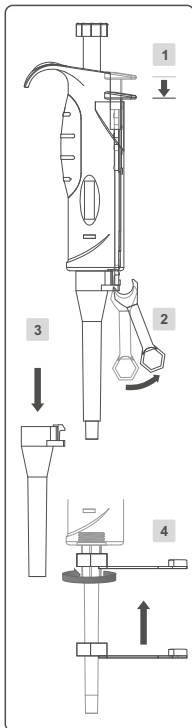

It is recommended to send the multi channel pipettes to your supplier or manufacturer for cleaning and greasing.

**Autoclaving** - The **pipet4u® pro** pipettes are fully autoclavable by steam at 121°C, 1.05 bar for 15 min. Autoclave the complete pipette without any disassembling. After autoclaving under the above mentioned conditions allow the pipette to cool and dry for 6 hours before use. It is not required to re-calibrate the pipette after autoclaving. If the pipette is autoclaved frequently, the piston and springs should be greased with the lubricant supplied with each pipette to maintain smooth movement. See section „Disassembling/reassembling and cleaning“.

**Calibration** - Each pipette calibration has been factory checked and certified according to EN ISO 8655. It is recommended to check the calibration at least once a year, for regularly used pipette.

**Checking calibration** - Performance testing should take place in a draught-free room with stable environment with relative humidity above 50 % and constant ( $\pm 0,5$  °C) temperature between 15 °C and 30 °C. The weighing vessel, pipette, tips and distilled water shall have stood in the room for a sufficient time, at least 2 hours, to reach equilibrium with the room conditions. Use an analytical balance with a readability of 0.01 mgs. 10 measurements for each test volume shall be carried out. The test volume for fixed volume pipettes is the nominal volume (greatest volume selectable by the user and specified by the manufacturer) and for variable volume pipettes at least three volumes shall be tested (nominal volume, 50 % of nominal volume, 10 % of nominal volume). For checking calibration of multi channel pipette, each channel should be considered as an individual pipette.

## Procedure

1. Select the test volume. Do not change the setting during the test cycle of 10 measurement.
2. Fit the selected tip(s) to the pipette cone(s).
3. Fill the tip(s) with distilled water and condition the pipette before testing by aspirating and dispensing the distilled water in the tip(s) five times. Afterwards discard the tip(s).
4. Attach a new tip(s) on the pipette cone(s) of pipette and pre-wet the tip(s) once.
5. Aspirate the distilled water and pipette it into the weighing vessel (use forward pipetting technique, page 8).
6. Weigh the pipetted quantity with an analytical balance and record the weight. Repeat the test cycle until 10 measurements have been recorded.
7. Convert the recorded masses to volumes, calculate the mean volume, systematic error and random error as described in EN ISO 8655-6:2002, part 8
8. Compare the systematic error (inaccuracy) and the random error (imprecision) with the values of specification table, page 16.

The calibration of the pipette must be set even if only one of the results falls outside the permitted range.

## Recalibration

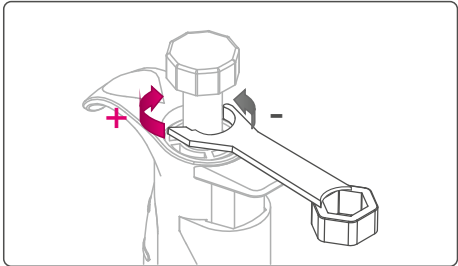

Place the calibration tool into the holes of the calibration adjustment lock (under the push button). Turn the adjustment lock anticlockwise to decrease and clockwise to increase the volume. Repeat checking calibration until the pipetting results are correct.

**Warranty** - Your **pipet4u® pro** pipette is warranted to be free from defects in material and workmanship for a period of 2 years from the date of purchase. Defects or damage caused by physical and/or chemical influences, consequences of normal wear and tear, as well as improper use are not covered by the warranty. The warranty is invalidated by non factory modification which will immediately terminate all liabilities on the manufacturer for the product or damages caused by its use. The buyer shall be responsible for the product or use of the product as well as any supervision required for safety. Routine cleaning and recalibration are not covered under the terms of warranty.

**Returning** - If requested the product must be returned to your supplier or manufacturer in well packed and insured manner. Before returning the pipette please make sure that the pipette is free from all contaminations. Please fill out the pipette complaint form (please ask your supplier or manufacturer for the form) and send it along with the pipette. All shipping charges must be paid by the buyer.

# Instruction manual

## Trouble shooting

Trouble	Possible Reason	Correction
Droplets left inside the tip	Unsuitable tip, non-uniform wetting of the plastic	Use new tip
Leakage or pipetted volume too small	Tip holder (cone) scratched or damaged	Change the tip cone
	Organic solvent as liquid	Aspirate and discard the organic solvent several times before actual pipetting by the same tip
	Tip incorrectly attached	Attach firmly
	Unsuitable tip	Use new tip
	Foreign particles between tip and tip cone	Clean the tip cone
	Insufficient amount of grease on piston and o-ring	Clean and grease o-ring and piston
Inaccuracies	O-ring not correctly positioned or damaged	Change the o-ring
	Incorrect operation	Follow instructions carefully
	Calibration altered	Recalibrate according to instruction
	Unsuitable for the particular liquid pipetting technique	Use correct pipetting technique
Push button jammed or moves erratically	Instrument damaged	Send for repair
	Piston contaminated Penetration of solvent vapours	Clean and grease O-ring and piston
Tip Ejector jammed or moves erratically	Tip cone contaminated from outside	Remove ejector collar and clean outer surface of tip cone with ethanol
Volume setting is not properly click stopped	Click stop mechanism damaged	Send for repair
Push Button does not turn for volume setting	Use of excessive force beyond the range of pipette	Send for repair

## Top assembly parts - pipet4u® pro Single channel pipettes

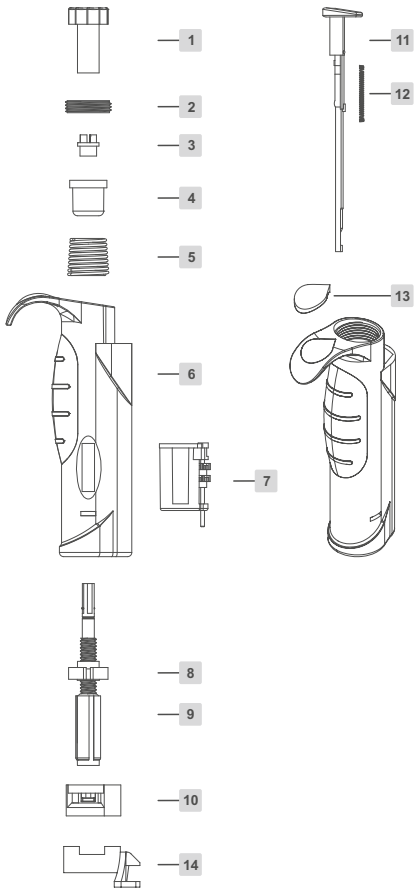

### Description

- |   |                        |    |                             |
|---|------------------------|----|-----------------------------|
| 1 | Push button            | 8  | Washer                      |
| 2 | Top closure            | 9  | Shaft                       |
| 3 | Spring stopper         | 10 | Bottom closure snap fitting |
| 4 | Primary spring support | 11 | Tip ejector                 |
| 5 | Spring primary         | 12 | Spring tip ejector          |
| 6 | Main body              | 13 | Drop                        |
| 7 | Counter                | 14 | Tip ejector pusher support  |

# Instruction manual

## Bottom assembly parts - pipet4u® pro

Single channel pipettes

Volume (µl)	Volume (µl)	Volume (µl)	Volume (µl)	Volume (µl)	Volume (µl)
0.1-2.5 /	5/10/20/	100/	200/	250/500/	2000/2500/
0.5-10/	25/50/	10-100	20-200/	1000/	5000/10000/
2-20	5-50		50-200	100-1000/	500-5000
				200-1000	2000-10000

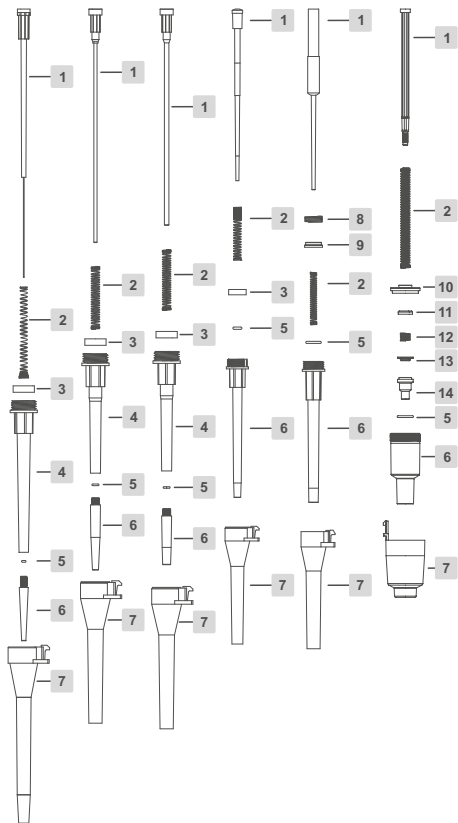

### Description

- |                                  |                            |
|----------------------------------|----------------------------|
| 1 Piston                         | 9 Secondary spring support |
| 2 Spring piston                  | 10 Washer (500-5000 µl)    |
| 3 Piston support                 | 11 Washer (500-5000 µl)    |
| 4 Tip cone top                   | 12 Spring (500-5000 µl)    |
| 5 O-ring                         | 13 Washer (500-5000 µl)    |
| 6 Tip cone                       | 14 O-ring holder           |
| 7 Ejector collar                 |                            |
| 8 Spring secondary (100-1000 µl) |                            |

**Note:** For 10000 µl and 2000-10000 µl pipettes tip ejection function is not available. Tip cone, washer (500-5000 µl) and o-ring holder are of different sizes for volume 500-5000µl and 2000-10000µl.

# Instruction manual

## Specifications

## Single channel pipettes variable volume

Volume Range	Increments	Test volume	Inaccuracy (±) %	Imprecision (±) %
0.1µl - 2.5µl	0.01µl	0.25µl	12.0 %	6.00 %
		1.25µl	3.0 %	3.00 %
		2.5µl	2.5 %	1.60 %
0.5µl - 10µl	0.1µl	1µl	2.5 %	1.50 %
		5µl	2.0 %	1.00 %
		10µl	1.0 %	0.80 %
2µl - 20µl	0.1µl	2µl	3.0 %	2.00 %
		10µl	1.5 %	1.00 %
		20µl	0.9 %	0.40 %
5µl - 50µl	0.5µl	5µl	2.0 %	2.00 %
		25µl	0.8 %	0.40 %
		50µl	0.6 %	0.30 %
10µl - 100µl	0.5µl	10µl	3.0 %	1.50 %
		50µl	1.0 %	0.50 %
		100µl	0.8 %	0.15 %
20µl - 200µl	1µl	20µl	2.0 %	0.80 %
		100µl	0.7 %	0.30 %
		200µl	0.6 %	0.15 %
50µl - 200µl	1µl	50µl	1.0 %	0.40 %
		100µl	0.8 %	0.20 %
		200µl	0.6 %	0.15 %
100µl - 1000µl	5µl	100µl	2.0 %	0.70 %
		500µl	1.0 %	0.40 %
		1000µl	0.6 %	0.20 %
200µl - 1000µl	5µl	200µl	0.9 %	0.30 %
		500µl	0.75 %	0.25 %
		1000µl	0.6 %	0.20 %
500µl - 5000µl	50µl	500µl	2.0 %	0.60 %
		2500µl	0.6 %	0.30 %
		5000µl	0.5 %	0.15 %
2000µl - 10000µl	100µl	2000µl	3.0 %	0.60 %
		5000µl	1.2 %	0.30 %
		10000µl	0.6 %	0.20 %

## Specifications

## fixed volume

Volume Range	Increments	Test volume	Inaccuracy (±) %	Imprecision (±) %
5µl	-	5µl	1.3 %	1.20 %
10µl	-	10µl	0.8 %	0.80 %
20µl	-	20µl	0.6 %	0.50 %
25µl	-	25µl	0.5 %	0.30 %
50µl	-	50µl	0.5 %	0.30 %
100µl	-	100µl	0.5 %	0.30 %
200µl	-	200µl	0.4 %	0.20 %
250µl	-	250µl	0.4 %	0.20 %
500µl	-	500µl	0.3 %	0.20 %
1000µl	-	1000µl	0.3 %	0.20 %
2000µl	-	2000µl	0.3 %	0.15 %
2500µl	-	2500µl	0.3 %	0.15 %
5000µl	-	5000µl	0.3 %	0.15 %
10000µl	-	10000µl	0.6 %	0.20 %

## Specifications

## 8- and 12-channel pipettes variable volume

Volume Range	Increments	Test volume	Inaccuracy (±) %	Imprecision (±) %
0.5-10µl	0.1µl	1µl	4.0 %	4.00 %
		5µl	2.5 %	2.50 %
		10µl	1.5 %	1.50 %
5-50µl	0.5µl	5µl	3.0 %	2.00 %
		25µl	1.5 %	1.00 %
		50µl	1.0 %	0.70 %
30-300µl	1µl	30µl	1.5 %	0.75 %
		150µl	1.0 %	0.50 %
		300µl	0.8 %	0.25 %

The 'ahn' logo features a stylized 'a' formed by a grey triangle pointing right and a magenta triangle pointing left, meeting at a central point. To the right of this graphic is the lowercase text 'ahn' in a magenta, sans-serif font, followed by a registered trademark symbol (®).

ahn<sup>®</sup>  
biotechnologie GmbH



**FMCG Industry Solutions Pty Ltd**  
ABN 22 135 446 007  
📍 Factory 11A, 1 - 3 Endeavour Rd, Caringbah NSW 2229  
🌐 [www.fmcgis.com.au](http://www.fmcgis.com.au)  
✉ [sales@fmcgis.com.au](mailto:sales@fmcgis.com.au)  
☎ 1300 628 104 or 02 9540 2288